



4710

Delay-On-Break Timing Module



The model 4710 is an all solid state timer that offers delay-on-break operation based on the status of an external initiate switch. Closure of the Initiate Switch energizes the remote load circuit and resets the timing to zero. The timing will remain reset until the initiate switch is opened, at which time a preset timing period begins. The load circuit remains energized until the timing period has elapsed, then de-energizes. Should the initiate switch be reclosed before the timing period has been completed, the timing cycle will reset and the load circuit will remain energized. The model 4710 is available in both fixed and adjustable models. The model 4710 is available in both DC and AC operating voltages.

Mechanical & Wiring

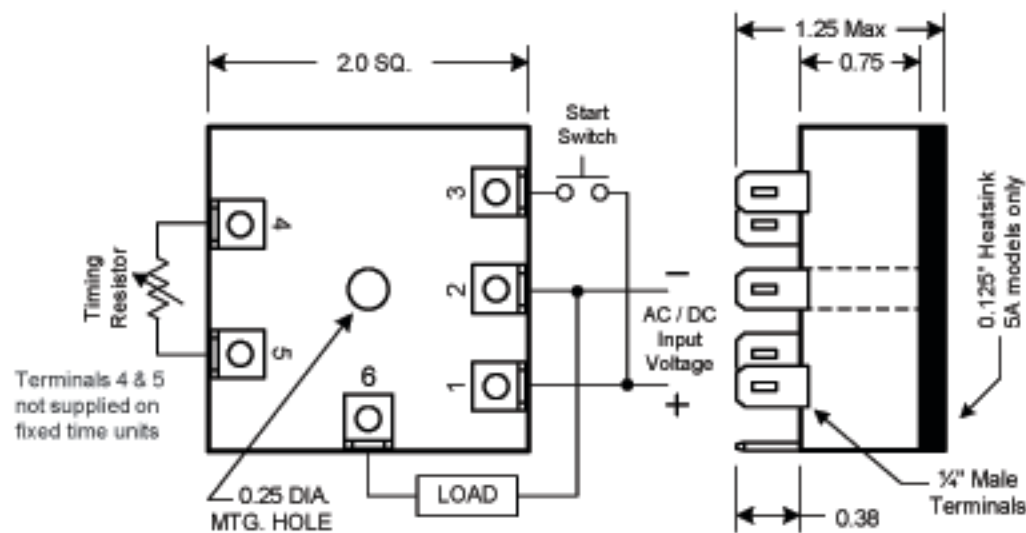

Timing Diagram

With Operating Voltage applied and the *Initiate Switch* open, the *Output* is OFF. At time #1, the *Initiate Switch* closes and the *Output* turns ON, energizing the load. At time #2 the *Initiate Switch* opens and the delay period begins. At time #3 the delay period ends, and the *Output* turns OFF. At time #4, the *Initiate Switch* closes and the *Output* turns ON, energizing the load. The *Initiate Switch* opens and closes at times #5, 6, 7, and 8, but re-closes before the end of the timing period keeping the *Output* ON and the load energized. At time #9 the *Initiate Switch* opens and remains open longer than the timing period causing the *Output* to turn OFF at time #10.

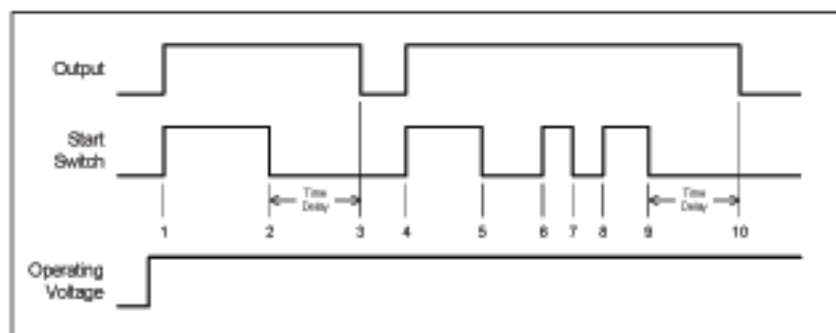

VISIT OUR WEB SITE AT: www.artisancontrols.com

Notice: Artisan Controls Corporation assumes no responsibility for customers applications or product design. The information and data contained herein is the sole and exclusive property of Artisan Controls Corporation. Any duplication, misuse, or conversion of this information without the express written consent of Artisan Controls Corporation is illegal and will result in damages including court costs and attorney fees being assessed against the party misusing this property.



Solid State Timers and Controllers

External Timing Resistor Chart

The left hand column lists five values of external resistors: 0 (short), 1 meg, 3 meg, 5 meg, and 10 meg, and across the top are listed the five model dash numbers, 1 through 5. To illustrate how the chart works assume that timing range -3 has been selected. Under the -3 column are the times that relate to the five values of external resistors. For an external resistor equal to 0 ohms, the time delay would be 2 seconds. With 1 meg ohm, 100 seconds and so forth up to 10 meg ohms where the time delay is 1000 seconds. If a 3 meg ohm potentiometer were connected across the external timing resistor terminals, you could expect, as a minimum, a time delay range of 2 to 300 seconds.

External Resistor (Ohms)	Timing Range Dash Number				
	-1	-2	-3	-4	-5
0	0.1	1	2	10	30
1 Meg	4	30	100	500	900
3 Meg	12	90	300	1,500	2,700
5 Meg	20	150	500	2,500	4,500
10 Meg	30	300	1,000	4,500	8,000

Ordering Information Fixed Timing Models

Part Number - Operating Voltage - Output Rating - Fixed Time in Seconds - Fixed Time Tolerance				
4710F	-2 (12VDC) -3 (24VDC) -4 (48VDC)	-A (1 Amp)	Specify the fixed timing period in seconds from 0.1 to 8000	-A (± 2%) -B (± 5%) -C (± 10%) -D (± 20%)
	-6 (24VAC) -7 (48VAC) -8 (120VAC) -9 (230VAC)	-A (1 Amp) -B (5 Amp) -C (1 Amp) -D (5 Amp) <small>-A & -B = DV switch (std) -C & -D = random switch</small>		

Ordering Information Adjustable Timing Models

Part Number - Operating Voltage - Output Rating - Timing Range			
4710A	-2 (12VDC) -3 (24VDC) -4 (48VDC)	-A (1 Amp)	-1 (0.1 - 30) -2 (1 - 300) -3 (2 - 1000) -4 (10 - 4500) -5 (30 - 8000)
	-6 (24VAC) -7 (48VAC) -8 (120VAC) -9 (230VAC)	-A (1 Amp) -B (5 Amp) -C (1 Amp) -D (5 Amp) <small>-A & -B = DV switch (std) -C & -D = random switch</small>	All times in seconds

VISIT OUR WEB SITE AT: www.artisancontrols.com

Notice: Artisan Controls Corporation assumes no responsibility for customers applications or product design. The information and data contained herein is the sole and exclusive property of Artisan Controls Corporation. Any duplication, misuse, or conversion of this information without the express written consent of Artisan Controls Corporation is illegal and will result in damages including court costs and attorney fees being assessed against the party misusing this property



Solid State Timers and Controllers

Specifications

Operating Voltage: 12V DC (10V - 18V DC) (-2), 24V DC (18V - 30V DC) (-3), 48V DC (40V - 56V DC) (-4), 24V AC (20V - 28V AC) (-6), 48V AC (42V - 52V AC) (-7), 115V AC (105V - 135V AC) (-8), 230V AC (208V - 250V AC) (-9) See *Ordering Information*.

Operating Current: Less than 20 milliamperes plus external load current.

Timing Mode: Delay-On-Break - initiate switch activated. Delay-On-Break Timing period is fixed or remotely adjustable. See *Ordering Information*.

Fixed Timing: Factory fixed at any timing period from 0.1 seconds to 8,000 seconds.

Tolerances On Fixed Timing: 2%, 5%, 10%, and 20% available, see *Ordering Information*.

Adjustable Timing Ranges: Twenty (20) ranges from five (5) models of adjustable delay-on-break timing from 0.1 seconds to 8,000 seconds. See *Ordering Information*.

Adjustable Timing Setting Accuracy: Time of remotely adjustable models will not deviate from the ideal timing shown on the *External Timing Resistor Chart* by more than $\pm 15\%$.

Timing Resistor Rating: Worst case power dissipation never exceeds 3 milliwatts.

Timing vs External Timing Resistor: See *External Timing Resistor Chart*.

Timing Variation: Less than 10% of set point over full temperature and voltage range.

Repeatability Of Timing Period: $\pm 1\%$ at stabilized operating voltage temperature.

Recycle Time: Operating voltage must be removed for a minimum of 200 milliseconds to assure that the timing and output circuits are reset.

Initiate Switch: Isolated SPST rated for 5 mA service - Load current does not flow through initiate switch.

Output Rating: -A and -C models rated for 70 milliamperes to 1 ampere inductive with inrush current to 15 amperes for 8 milliseconds. -B and -D AC models rated for 70 milliamperes to 5 ampere inductive with inrush current to 40 amperes for 8 milliseconds.

AC Zero Voltage Switching: -A & -B AC models provide zero voltage switching within ± 50 microseconds of zero volts (standard), -C & -D models provide random voltage switching.

Extending Rating On AC Model: Operation of AC models can be extended to 10 amperes by mounting the timer heatsink base on a metal surface and maintaining the heat sink temperature less than 90°C.

Output ON Voltage Drop: 3 volts max. at full rated current for AC models, 4 volts for DC models.

Output OFF Leakage Current : 2 mA maximum for DC models, 4 mA maximum for AC models.

Transient Protection: Output Switch protected by silicon transient suppressors responding to transients within 1×10^{-12} seconds to a peak pulse power dissipation of 1500 watts, with transient surge currents to 200 amperes for durations up to 1/120 second at 25½ C. Maximum transient voltage protection is 6000 volts as delivered through a source resistance of 30 ohms with a maximum duration of 8.3ms.

Dielectric: 1500V rms all terminals to case.

Operating Temperature: -20°C to +85°C

Construction: Encapsulated module with .25 quick connect wiring terminals.

Agency Recognitions: UL File E47858, Component Appliance Controls ATNZ2 & ATNZ8 (US & Can), Component Auxiliary Devices NKCR2 & NKCR8.

Data Sheet Revision Date: August 8, 2006

VISIT OUR WEB SITE AT: www.artisancontrols.com

Notice: Artisan Controls Corporation assumes no responsibility for customers applications or product design. The information and data contained herein is the sole and exclusive property of Artisan Controls Corporation. Any duplication, misuse, or conversion of this information without the express written consent of Artisan Controls Corporation is illegal and will result in damages including court costs and attorney fees being assessed against the party misusing this property